



Poseidon EBS MkII / Sea Air EBS MkII
User Manual

VERSION 1.8



The Poseidon EBS MkII / Sea Air EBS MkII

This Poseidon EBS MkII/Sea Air EBS MkII is an EN 4856 Category A underwater escape device.

Before use always check position 10-12 on page 6 and 7 in this manual.

Complete service of the Poseidon EBS should be made every 24th month or if the EBS is used in training purpose the complete service should be made every 6th month by Poseidon Diving System AB or approved service station/person.

The Poseidon EBS is intended for use as a generic underwater escape device but can be used as a helicopter escape device to assist aircrew members or passengers in making an emergency egress from a submerged aircraft. Due to its limited air volume, it is not intended egressing from depths greater than 10 meters.

Poseidon article number 5000-015
Manufactured by Poseidon Diving Systems AB.

Poseidon article number 0140-010.

All part in the EBS are individually tested according to EN250 Cold. The EBS unit is tested and approved according to CAP1034.

The EBS system is certified vs applicable parts of the EN4856:2018.

Poseidon Diving Systems American Distributor
274 West Drive, Melbourne, FL 32904
321.821.4724 www.helicopterhelmet.com

WARNING:

Retain this manual for your reference. Review this manual periodically. Improper use, or misuse, of this device could result in serious injury or even death.

Text, photographs and figures copyright © 2008-2023 by Poseidon Diving Systems AB. ALL RIGHTS RESERVED.

Manual Version 1.8 - march 2023. Valid from production date 2023.



Approvals/Certifications

The Poseidon EBS MkII/Sea Air EBS MkII is approved according to PPE Regulation 2016/425 (see Technical Data for full detail).

EU TYPE-EXAMINATION CERTIFICATE
CERTIFICATE

No. 0598/PPE/23/2209 :

SGS Fimko OY,
Takomotie 8,
FI-00380 Helsinki,
Finland
Notified body number 0598

UKCA TYPE-EXAMINATION

0120/PPE/230083
*SGS United Kingdom Limited,
Rossmore Business Park,
Ellesmere Port,
Cheshire CH65 3EN, UK
Approved body number 0120*

Production quality assessment
according to regulation
Module D is assessed by:

SGS Fimko OY,
Takomotie 8,
FI-00380 Helsinki,
Finland
Notified body number 0598

www.poseidon.com/en-se/support/docs/



Poseidon Diving Systems AB is certified according to ISO 9001



Functional overview





Cylinder valve in position OPEN
Turning the valve handle counter clockwise until stop.
Green color in the hole indicate OPEN position.

Assembly

Inspect the o-ring on the 1st stage tank thread and make sure that sealing surfaces are clean and that the o-ring is lubricated with approved Poseidon product (art no 8516).

Mount the 1st stage on the bottle tight and firmly (rec. 60 Nm).

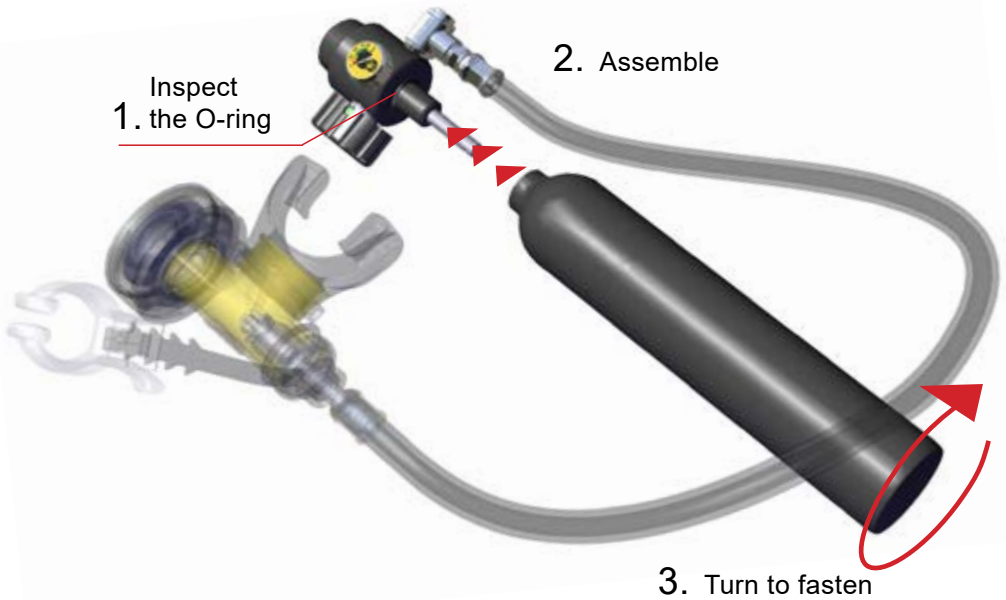

WARNING:



Before assembly, make sure all components are intact and without any visible damage. Do not use if there is any sign of damage to the equipment. Repair of any component should only be performed by a service technician that is authorized to service/repair the equipment. Do not try to repair any component without proper training.

Filling instructions

Recommended filling pressure is 232 bar/ 3365 psi.
Maximum filling pressure is 232 bar/ 3365 psi.
Use Poseidon filling adapter art no 0800-015.



Connection per
ISO 12209-2 232 bar

Purge button

1. Close the cylinder valve. Press the purge-button on the 2nd stage to ensure that the breathing apparatus is depressurized before the filling process begins.



2. Remove the blanking plug from the 1st stage.
Inspect the O-ring and attach the filling adapter to the 7/16" HP port where the blanking plug was mounted. Make sure the filling adapter is firmly attached.
Attach the filling hose to the ISO 12209-2 232 bar thread on the filling adapter.



3. When the filling hose is firmly attached to the filling adapter, slowly open the valve on the 1st stage by turning the valve handle counter clockwise.
4. Slowly open the filling source valve and make sure there are no leakage. Fill the Poseidon EBS to 232 bar/ 3365 psi. Maximum filling pressure is 232 bar/ 3365 psi.
5. When the Poseidon EBS is filled, close the valve on the filling source.

WARNING:

Before you start filling the bottle, make sure you are well familiarized with these instructions.

Maximum pressure of 232 bar/ 3365 psi.

Failure to follow these instructions may lead to injury or death.



6. Close the valve on the Poseidon EBS

7. Release the pressure by using the purge button on the 2nd stage.

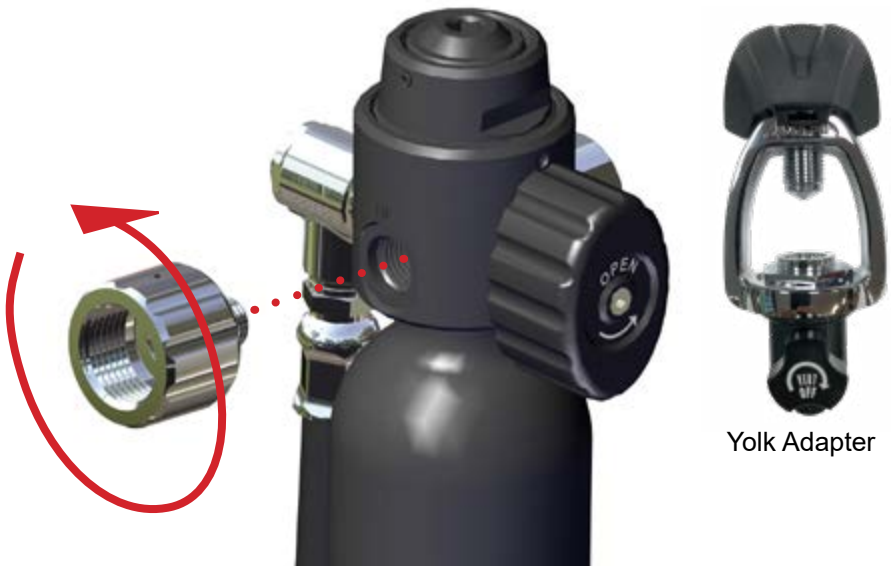

8. Unscrew the filling adapter/hose from the Poseidon EBS.



9. Mount the blanking plug in to the 7/16" HP port of the 1st stage and make sure it's firmly attached. Before mounting the blanking plug, inspect the o-ring to make sure it's without any flaws, make sure the o-ring is lubricated and that all sealing surfaces are clean and undamaged.



10. Open the valve [1] on the Poseidon EBS and check the pressure. If pressure is 232 bar/ 3365 psi [2] it's OK to use. If the pressure is below 232 bar / 3365 psi, start the filling procedure from pos 1 on page 4.



11. Attach the Nose Clip in correct position on Nose Clip Holder.

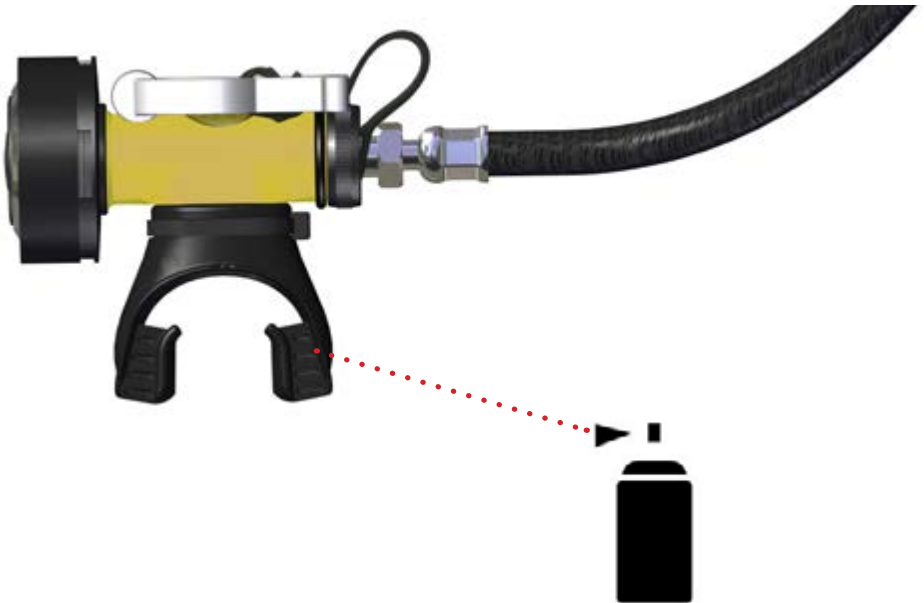

12. Spray the mouthpiece with GUARDIAN SUPERIOR™ disinfection, Art.no 0050-127 (or other Poseidon approved product). Use 2-3 sprays and wipe with a cloth or piece of paper.

13. The Poseidon EBS MkII/Sea Air EBS MkII is now ready for use.



WARNING:



Before use, make sure all components are intact and without any visible damage. Do not use if there is any sign of damage to the equipment. Repair of any component should only be performed by a service technician that is authorized to service/repair the equipment. Do not try to repair any component without proper training.



IMPORTANT:

The EBS MkII system should ALWAYS be pressurized and mounted in its designated pocket before the start of the mission so that it's ready for use if/when needed.

It's NOT good practice to pressurize the EBS MkII system during ditching.



We RECOMMEND the use of adjustable pockets that hold the cylinder securely in all cases, with good access to the opening/closing valve.

The second stage must be securely and fixed as close to the muzzle as possible, so that the procedure to bring it to the muzzle is simple and quick in all circumstances.

It is important that we calculate well the distance of the hose from the cylinder to the second stage. This has to be loose so that it allows the maneuver of use without being tight in any case, nor too loose.

Preparations before use / Before Flying

When pressurizing the EBS MkII system, the following method/steps should be used/taken:

- Make sure you have a firm grip on the cylinder and 2nd stage / LP hose or that the EBS MkII system is firmly secured in its designated pocket on the survival suit or harness before pressurizing the system.
- Open the valve and check the air pressure in the cylinder.
- Check the ditching procedure, taking the second stage from its housing to the mouth.
- Put the second stage back in place. We recommend Velcro or rubber bands to hold the second stage in place and prevent us from being unable to detach it from its housing.
- Take some time to listen/feel for possible pressure losses.

The system is now ready for use.

Deploying the EBS

In the event of an emergency, deploy the EBS in the following way:

1. Grab the 2nd stage regulator with a free hand and insert it into your mouth.
2. If submerged the 2nd stage regulator needs to be purged by pressing the purge button smoothly.
3. Start to breath normally while you put the nose clip onto your nose using your thumb and index finger.
4. Continue to breath from the EBS until are you are in a safe location (surface).
5. Please remember that the gas supply is limited and try to breath normally.

After Use / After Flying

- Close the valve.
- Press the purge button of the second stage.
- The system can be stored with the vest without problems but be aware of refilling it after four activations without use, as purging causes air to be lost from the cylinder.

The regulator should always be rinsed while it is still mounted on the tank. The regulator should be under pressure, otherwise water can enter either the first or the second stage and cause the build up during next usage. If water enters your first stage, corrosion could form inside the first stage leading to loss in performance and/or failure. If you suspect water has entered the first stage we recommend that you let a service technician, certified to service/repair Poseidon equipment, disassemble your first stage to dry and clean it.

- The regulator should be rinsed in fresh water after every dive so as to avoid salt crystal formation around the functional parts. Purge the second stage while you rinse it, to allow fresh water to access all parts of the second stage.
- Blow the equipment dry by using air pressure.
- After rinsing, close the cylinder valve and purge the regulator.
- Pack and store your regulator in a protected area/case/bag. This protects the regulator from damage. It is especially important to protect the connection areas.
The regulator should not be stored in direct sunlight and/or at high temperatures.

Safety Instructions and Faults

- Do NOT pressurize the EBS MkII system while the 2nd stage and LP hose is hanging free in the air. Pressurizing the EBS MkII system while the LP hose and 2nd stage are hanging free in the air may lead to injuries.
- When pressurizing an EBS MkII system, movement in the LP hose is normal, as the LP hose is filled with a pressure of around 10 bar / 145 psi. The 2nd stage may also make some noises.
- If there is a “machine gun-like” sound from the 2nd stage when the system is pressurized, it’s because the Over Pressure Valve (OPV) in the 2nd stage is activated due to the pressure in the LP hose being too high. Close the valve on the EBS MkII 1st stage and purge the 2nd stage. The EBS MkII 1st stage needs servicing and re-adjustment.
- If you hear or feel any leakage during the pre-flight check, no matter how small, please replace the EBS, and send it to technical support

WARNING:



The EBS shall be serviced and maintained on a regular basis by trained and authorized technicians. The cylinder must be inspected and serviced in accordance with all local governing agencies.

The regulator components must be serviced according to service manual. Failure to do so creates an unsafe condition that could lead to serious injury or death.

Transport

Before transportation make sure that the EBS is properly padded in a dry bag/ box that prevents the equipment from being damaged. Its especially important to protect the 2nd stage regulator.

Technical data

General	
<i>Maximum Operational depth</i>	<i>Certified to 10 m (33 ft)</i>
<i>Approved gas</i>	<i>Air according to EN12021</i>
<i>Maximum working pressure</i>	<i>232 Bar (3365 psi)</i>
<i>Cold water performance</i>	<i>>4deg C</i>
<i>Cleaned to hydrocarbon levels <50mg/m²</i>	<i>No</i>
<i>O-ring materials</i>	<i>Nitrile, EPDM</i>
<i>Lubricants</i>	<i>Poseidon Regulator grease 8516 & silicone oil.</i>
<i>Warranty</i>	<i>12 months</i>
<i>Total weight</i>	<i>914 g / 32,3 Oz</i>

2and stage	
<i>Flow Rate</i>	<i>1250 l/min / 44 cuft min</i>
<i>Technique</i>	<i>Downstream</i>
<i>Safety valve opening pressure</i>	<i>15 +/- 1 bar (217 +/- 14 psi)</i>
<i>Swivelling</i>	<i>Around axis, can be used either side</i>
<i>Material</i>	<i>ASA, Brass, TPU, Silicone, PU</i>
<i>Venturi assist</i>	<i>Automatic</i>
<i>Inhalation control</i>	<i>Automatic</i>
<i>Anatomic mouthpiece</i>	<i>4532 Poseidon AIR</i>

1st stage Poseidon Cyklon	
<i>Flowrate (l/min)</i>	<i>>1700 l/min / 180 cuft/min</i>
<i>Nominal inter-stage pressure</i>	<i>11.5 bar (167 psi)</i>
<i>Technique</i>	<i>Diaphragm</i>
<i>Valve technique</i>	<i>Piston Valve</i>
<i>Seat material</i>	<i>Polyetereterketon</i>
<i>Test pressure</i>	<i>450 bar (6526 psi)</i>
<i>Ports</i>	<i>1 LP (UNF 3/8") / 2 HP (UNF 7/16")</i>
<i>Cylinder connection</i>	<i>UNF 5/8"-18</i>
<i>Built in OPV</i>	<i>In 2:nd Stage</i>
<i>Material</i>	<i>Brass, plastics, stainless steel and aluminium</i>

Hose	
<i>Standard lengths hose</i>	<i>24 inch / 61 cm</i>
<i>Burst pressure</i>	<i>>100 bar (1450 psi)</i>
<i>Pull strength</i>	<i>>1000 Newton (225 lbf)</i>

Cylinder	
<i>Cylinder Volume</i>	<i>0,4 l</i>
<i>Cylinder Material</i>	<i>Aluminium</i>
<i>Cylinder Length with Regulator</i>	<i>29,5 cm</i>
<i>Rated Cylinder Pressure</i>	<i>According to composite cylinder specification</i>
<i>Cylinder Approval</i>	<i>EN1975 (PED)</i>

Performance during testing

Equipment Performance

—Ansti—	Swedish Navy	—Ansti—	
Certificate Reference	LSTF-0917_20160620_141741		
Date : 2016-06-20		Time : 14:17:41	
<hr/>			
Equipment			
Regulator Type	A15 16-06 Poseidon EBS		
Serial Number			
Interstage Pressure Static	0.00 barg		
<hr/>			
Conditions of Test			
	Mean	Min	Max
Room Temperature (C)	20.0		
Exhale Temp (C)	16.8	16.5	17.1
Water Temp (C)	3.8	3.8	3.8
Humidity (% RH)	0.1	0.0	0.2
HP Supply Pressure (barg)	0.4	0.2	0.6
Tidal Volume (litre)	2.50	2.50	2.50
Breath Rate (bpm)	25.03	24.81	25.20
Ventilation Rate (lpm)	62.47	61.93	62.89
<hr/>			
Results (3 Loops)			
	Mean	Min	Max
Inhale Pressure (mbar)	9.52	9.41	9.61
Inhale Pos Pressure (mbar)	0.73	0.59	0.83
Exhale Pressure (mbar)	9.13	9.11	9.16
Ext Work of Breathing (J/l)	1.42	1.40	1.45
Inhale Work (J/l)	0.73	0.71	0.75
Pos Inhale Work (J/l)	0.00	0.00	0.00
Exhale Work (J/l)	0.69	0.69	0.69

Pressure - Volume Diagrams at Mean Depth of : 4.1 msw (13.5 fsw)

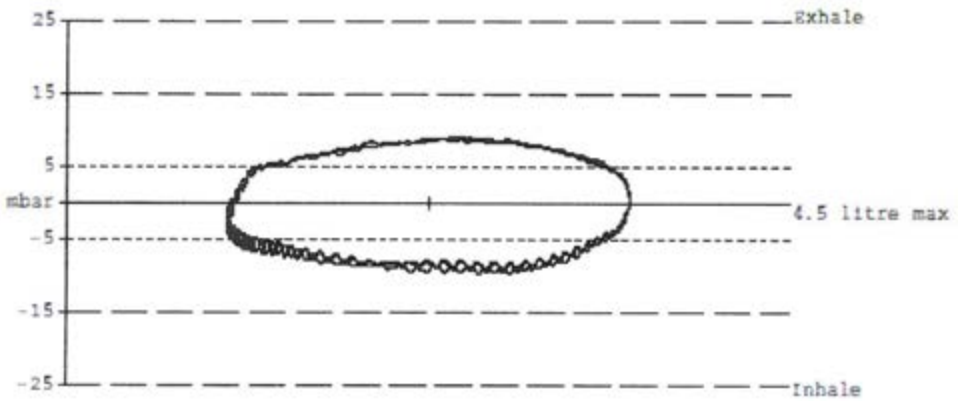

Components



Spare parts list

Part no.	Description
0131-001	Filling hose, 300-200 bar incl safety valve 225 bar
0400-135	Cylinder, Black 0,4 l Alu, UNF 5/8"-18, 232 bar/3365 psi
001-95	Pressure gauge
0130-029	Low Pressure Hose 24"
0005-009	Mouthpiece
0050-127	Desinfection, Guardian Superior 100 ml
0009-013	Nose clip
0800-015	Filling adapter Poseidon EBS 7/16" - G5/8"
8516	Lubricant, tube 10 grams
0013-165	O-ring HP port, Pressure gauge and blanking plug
0012-138	O-ring 1:st stage tank thread
0013-164	O-ring LP port (hose connection)
0010-112	O-ring, Nose Clip Holder
LRS2256	Refill Adapter - Yoke Version
LRS3256	Refill Adapter - Compressor Version

Declaration of conformity:
<https://poseidon.com/docs>

This PPE protects the user from the following risks:

- Drowning
- Various nuisance factors
- Usage of materials that can affect the human body
- Design defects
- Incorrect use

www.poseidon.com

Maintance History



Importer
Distributor
Service Center

274 West Drive
Melbourne, Florida 32904
Phone 324.821.4724
www.helicopterhelmet.com